

DEIST

Safety



**CELEBRATING MORE THAN
40 YEARS**

IN RACING SAFETY!

\$3.00

THE DEIST STORY

Celebrating Over 40 Years Of

Jim Deist is universally recognized as the premiere exponent in racing safety. He is personally responsible for developing many products that have become standard in competition and recreational motorsports.

In honor of his many life-saving innovations and years of untiring service to the industry, Jim Deist was inducted into the SEMA "Hall Of Fame" and received NHRA's Lifetime Achievement award.

The Deist Safety story began in the late 50's, when Jim Deist applied his years of experience in aircraft safety to motorsports. He is credited with developing the first firesuit and successful drag chute...which led to the formation of Deist Safety in 1958.

Deist Safety was instrumental in the development of the first "Meets SEMA Specs" program which is currently administered by SFI.



To this day, Deist Safety maintains the most complete safety equipment testing laboratory in the industry, and uses it to continually develop and refine new products to benefit all forms of motorsports. Some of Jim Deist's other innovations include arm restraints, tailgate nets, shock tows, lower engine containment device and the Duck-Bill®.

Moreover, Deist Safety has established close ties with the technical arms of all major sanctioning bodies (including **CART, IMSA, NASCAR, NHRA, SCORE, HDRA, SCCA** and **USAC**) to ensure the administration of proper safety standards.

Jim Deist has dedicated his life to saving the lives of others. This dedication is reflected in the excellence of each and every product that carries the familiar Deist Safety logo.

CATALOG INDEX

The Deist Story	Page 2
Driving Suits	Pages 3-7
Custom Suits	Page 6
Driving Suit Accessories	Page 7
Driving Boots and Gloves	Page 8
Crew Apparel	Page 9
Sportswear and Accessories	Page 10
Belts, Harnesses and Hardware	Pages 11-17
Tie Down Straps	Pages 18-19
Helmets	Page 20
On Board Fire Systems	Page 21
Transmission Blankets & Lower Engine Containment Device	Page 22
Blower Restraints	Page 23
Fuel Cells, Jugs and Accessories	Page 24
Drag Chutes	Page 25
Top Fuel Suits and Accessories	Page 26
Marine	Page 27
Jr. Dragster	Page 28
Sprint and Kartings	Page 29
Off Road	Page 30
Stock Car	Page 31

2.



Special Thanks To:
 Marian Deist, Jim Kerr, Kirk Miller, Mike Waterhouse,
 Timothy Dahlum, Carole Hansen, Joe & Dee Hansen and Ron Johnson

Order Line: (800) 383-3478 | Tech Line: (818) 240-7866 | Fax Line: (818) 244-9230

DRIVING SUITS

SUIT SIZING CHART

1-Piece Suit	Chest	Waist	Hips	Inseam	Back of Neck Down To Waist
Men's Small	36"-38"	30"-32"	35"-37"	28"-31"	18"-19"
Men's Medium	38"-42"	32"-36"	37"-39"	30"-31"	18"-19"
Men's Large	42"-46"	38"-40"	41"-44"	30"-31"	18"-19"
Men's X-Large	46"-50"	41"-44"	45"-47"	30"-31"	20"-21"

Jacket (2-Piece Suit)	Chest
Small	34"-36"
Medium	38"-40"
Large	42"-44"
X-Large	46"-48"
XX-Large	50"-52"

SUIT SIZING

Use this table to determine which size best suits your needs. Those drivers who do not fit within standard "Off-The-Rack" sizes, we suggest custom-tailored suits.

Pants 2-Piece Suit	Waist	Hips	Thigh	Inseam
Small	28"-31"	38"	22"	32"
Medium	32"-35"	40"	24"	32"
Large	36"-39"	44"	26"	32"
X-Large	40"-44"	48"	28"	32"



STANDARD NOMEX COLORS

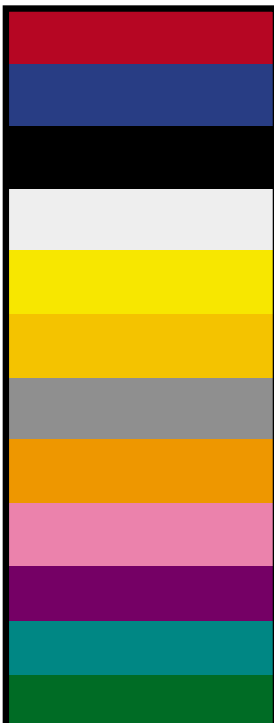

Choice Of Colors:

Standard one piece and two piece suits are available in Red, Blue or Black. Custom colors shown are available at an additional charge. Standard suits are one solid color with contrasting trim. Any available Nomex® color may be combined to make custom suits.

IMPORTANT

Due to differences in material dye lots, the effects of sun fading and dry cleaning, it is impossible to guarantee a color match when uniforms are ordered at different times. Please take this into consideration when ordering.



DRIVING SUITS

Deist Safety driving suits are manufactured to meet one of the following specifications SFI-3/2A-1, 5, 15, 20 and FIA. Please provide specific requirements for your racing organization!



SINGLE LAYER FIRE RETARDANT COTTON JACKETS / PANTS / DRIVING SUITS

Built to meet SFI 3/2A-1 specifications. These single-layer driving suits made from **Indura®** Fire Retardant Cotton are available in a one piece design or a separate jacket and pants combination. Deist's one piece suit features the "Action Back" with elastic waistband, Nomex® wrist and ankle cuffs and two way Nomex® zipper with pressure sensitive fastener neck closure and two pants pockets. Machine washable. **SFI tag** optional at an additional charge. Standard sizes: Small, Medium, Large or Extra Large. Colors: Red, Blue or Black. **Custom colors available at an additional charge.**

00200 Series for one piece suit

01200 Series for two piece suit

For suit size chart refer to page 3.



INDURA CUSTOM FIRE RETARDANT COTTON COLORS



Order Line: (800) 383-3478 | Tech Line: (818) 240-7866 | Fax Line: (818) 244-9230

DRIVING SUITS

Deist Safety driving suits are manufactured to meet one of the following specifications SFI-3/2A-1, 5, 15, 20 and FIA. Please provide specific requirements for your racing organization!



SINGLE LAYER NOMEMX® JACKETS / PANTS / DRIVING SUITS

Built to meet SFI 3/2A-1 specs. Single-layer Nomex®, driving suits are available in a one piece design or separate jacket and pants combination. Deist's one piece features the "Action Back" with elastic waistband, Nomex® wrist and ankle cuffs and Nomex® two-way zipper with pressure sensitive fastener neck closure and two front pockets. Standard sizes: Small, Medium, Large and Extra Large. Stocking Colors: Red, Blue or Black.

00300 Series for one piece suit
01500 Series for two piece suit

DOUBLE LAYER NOMEMX® / KEVLAR® JACKETS / PANTS / DRIVING SUITS

Built to meet SFI 3/2A-5 specs. Two layer Nomex®/Kevlar®, driving suits are available in a one piece design or separate jacket and pants combination. These quality designed Nomex® suits provide approximately 200% more protection than single layer suits. Standard sizes: Small, Medium, Large and Extra Large. Stocking Colors: Red, Blue or Black.

00400 Series for one piece suit.
01700 Series for two piece suit.

THREE LAYER NOMEMX® / KYNOL® / NOMEMX® JACKETS / PANTS / DRIVING SUITS

Built to exceed SFI 3/2A-5 specs. Three layer Nomex®-Kynol®-Nomex® driving suits provide approximately 500% more protection than single layer suits. Standard sizes: Small, Medium, Large and Extra Large. Stocking Colors: Red, Blue or Black.

00700 Series for one piece suit
01800 Series for two piece suit

GO KARTERS, SPRINTERS & JR. DRAGSTERS
See pages 28 & 29 for more details.

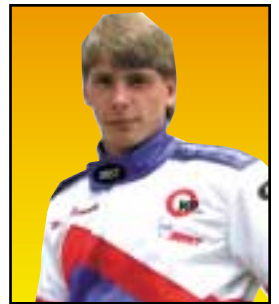

Custom colors available at an additional charge. For suit size chart see page 3

NOTE: It is highly recommended that Nomex® underwear be worn in conjunction with all driving suits, especially single-layer 3-2A/1 garments. Please see underwear P/N 03310 and 03410 for details (page 7).



CUSTOM SUITS

CUSTOM TAILORED AND SPECIAL COLOR DRIVING SUITS

Custom Nomex® driving suits. One piece and two piece available in a wide array of color choices. Design your own, or let our design team assist you. (Special order/measurement form required).



ELIMINATOR

Two color suit with contrasting trim.



DOMINATOR

Dominate your competition with your wildest design, total free form.



ANNIHILATOR

Multi colored suit trim in multi angle design.



PREDATOR

Multi colored suit diagonal, horizontal or straight line designs.



CUSTOM EMBROIDERY

Custom embroidery available...from mild to wild to fit your particular taste. Deist offers a full range of embroidery options to service your needs, including: standard embroidery, custom logo digitizing or hand embroidery all at an affordable price.



CHALLENGER

Single color suit with contrasting trim.

6.



Order Line: (800) 383-3478 | Tech Line: (818) 240-7866 | Fax Line: (818) 244-9230

DRIVING SUIT ACCESSORIES

CUSTOM SUITS



KOOL VEST™



The Kool-Vest can be used with any driving suit. It has

compartments across the shoulder blades and on each side of the vest to hold the Kool-Pads™. We recommend a spare set of pads to be frozen in dry ice while the others are in use.

- 03520 Kool vest with 3 Kool-Pads™
- 03520.3 Replacement Kool-Pads™ Each

"KOOL SUIT OPTION"

You can order any Deist driving suit with special inside pockets to accept Deist's highly effective "Kool-Pads™". The pads are kept frozen, and slipped into the suit just prior to the race.



NOMEX® UNDERWEAR

Provides an extra layer of comfort and protection. Comes in separate tops and bottoms to assure a good fit. Tops feature long sleeves and knit cuffs. Bottoms are form-fitting with ankle cuffs.

- 03310 Nomex® Top (State Size: Small, Medium, Large, XL & XXL).
- 03410 Nomex® Bottom (State Size: Small, Medium, Large, XL & XXL).
- 03500 Nomex® Socks (State Shoe Size: 6-13.)

It is highly recommended to wear Nomex® under wear with all suits, especially single and double layer driving suits.

Deist Custom Driving Suits meet all safety requirements for FIA, SCCA, SFI, IMSA, NASCAR, NHRA, IHRA and most other racing organizations. Custom suits come standard with shoulder epaulets. Deist's exclusive "Action-Back" design, elastic waistband, front pants pockets, Nomex® two-way zipper with protective flap, pressure-sensitive fastener neck



closure, knit Nomex® ankle and wrist cuffs.



ADDITIONAL OPTIONS AVAILABLE ON CUSTOM DRIVING SUITS

1. Soft Collar/Shirt Collar
2. Raglan Sleeve
3. 3-Point Epaulet (box sleeve only)
4. Wedge Stretch Sleeve
5. Full Circle Stretch Sleeve
6. Boot Cut (straight leg cuffs)
7. Kool Pockets
8. Jacket Pockets
9. Pants Back Pockets
10. Sewn-In Restraints
11. Box quilts
12. Contrasting Thread
13. Knit Lower Back Panel
14. XXL & Larger Sizes
15. SFI & FIA Tags

NOMEX® HOODS

Designed to be worn under the helmet, these knit hoods provide an extra measure of protection.

- 03210-Nomex® Hood (2 layer) SFI 3.3.1
- 03211-Nomex® Hood (1 layer)



Order Line: (800) 383-3478 | Tech Line: (818) 240-7866 | Fax Line: (818) 244-9230

DRIVING BOOTS & GLOVES



LEATHER CREW SHOES

Designed to meet the rugged needs of today's winning teams, along with the comfort required for everyday use. Men's sizes 6 to 13 and in half sizes.

05000 Leather Crew Shoe Black or Gray.

HI-TOP BOOTS

These high top boots provide both excellent protection and maximum driver comfort. The high top provides additional support, while a double overlapping flap with velcro closure adds an extra safety factor. Available in Men's size 6 to 13 and in half sizes. Black, Red or Blue.



NOMEX® /KYNOL® T/F BOOTS

Similar in construction to the 3-2A/20 fuel suit. These boots feature a hand sewn moccasin style sole for extra durability. Available in Men's size 6 to 13. Standard colors, Black, Red or Blue. Custom colors available.

84400 Top Fuel boots SFI 3.3/20
See page 26 for more details.



MID-TOP BOOT

Deist Safety now offers the ultimate in safety, comfort and style! Our new line of suede driving boots are available in a mid top and high top design. Boots are lined with a padded Kevlar® inner liner and have a Non-Skid

Rubber Sole. Available in Men's size 6 to 13 and in half sizes. Black, Red, Gray or Blue.

06000 Mid Top Driving Boots SFI 3.3/5



DRIVING GLOVES

Deist offers a wide variety of driving gloves to assure proper protection for each particular application. These include single, double and even multi-layer gloves in a variety of colors. Multi-layer Nomex® gloves come with special palm lining to provide optimum grip of steering wheel and other controls. Please see glove size conversion chart below to determine fit.



04100



04100.331



04200



84600

SINGLE-LAYER NOMEX®

Knit Nomex® back with leather palm. Available in Red, Blue or Black. Custom colors available by special order.

04100 Single-Layer Nomex® Glove Leather Palm

04100.331-Nomex Back, Nomex® under Leather Palm (SFI 3.3/1)

DOUBLE-LAYER NOMEX®

The double-layer glove affords excellent protection while maintaining high levels of comfort and flexibility. Has padded calfskin palm and fingers with Nomex® gauntlet. Available in Red, Blue or Black Nomex®.

04200 Double Layer Nomex® Glove (SFI 3.3/5)

MULTI LAYER NOMEX®

Deist offers these special gloves that feature multi-layers of Nomex® and Kynol®. All Multi-layer gloves come with special palm lining to provide optimum grip of steering wheel and other controls. Available in Red, Blue or Black.

84600 Top Fuel Glove (SFI 3.3/20)

GLOVE SIZE CONVERSION CHART

Lay hand flat, with fingers together, Measure circumference at widest point of hand (usually at middle of thumb).
8"= Small, 9"= Medium, 10"= Large, 11"= X-Large.



04300

REFUELING GLOVES

Knit Nomex® back, exclusive "Fuel Barrier" and leather palm. Available in Red, Blue or Black. Custom colors available.

See page 31 for more details.

04300 Refueling Gloves

Order Line: (800) 383-3478 | Tech Line: (818) 240-7866 | Fax Line: (818) 244-9230

CREW APPAREL



STANDARD ECONOMY CREW SHIRTS

Our economy Crew Shirts help to sharpen your team image at an affordable price. This is one of our "HI-PROFILE" products for marketing company & sponsor.

02100 Crew Shirts Standard (Economy)

02200 Crew Shirts (Custom)

02300 Crew Pants Standard

02305 Crew Shorts Standard

Custom Pants & Shorts Available



Custom Shirts



Crew shirts provide an excellent opportunity to market your team name or sponsor involvement. Let your team uniforms speak for themselves. Deist provides an unlimited array of complete team and crew uniform styles. Custom assembled and tailored to fit every discriminating taste & budget.



DEIST HAT

02600 Deist Hat

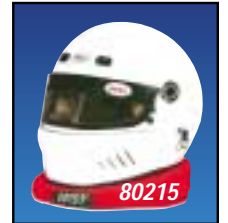
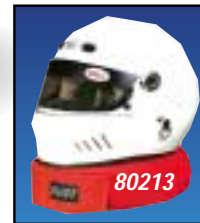

80213

80215

HELMET SUPPORT

Used to support the weight of the helmet, thereby reducing neck fatigue. This full 360 degree design provides forward/back and side-to-side support. Nomex® covered with zipper closure over fire retardant foam. Velcro front closure. Standard sizes: Small (14"), Medium (15"), Large (17") and Extra Large (19"). Stock Colors: Red, Blue or Black. Other colors available by special order.

80213 Full circle 3" thick.

80215 Wedge shape 3" in back 1-1/2" in front.

CORDURA EQUIPMENT BAGS

08695 Helmet Bag
(16" X 16" X 10")

08691 Racer Bag
(8-1/2" X 25-1/2" X 11-1/2")



08690-6103

CUSTOM EQUIPMENT BAGS MADE TO FIT ANY NEED.



SPORTSWEAR & ACCESSORIES



DRIVING GLASSES

Wear the most advanced driving glasses on the race track, NASA developed haze reduction optical wear for the space program. Wear a pair of these driving glasses, and the road ahead becomes clear, sharp, and glare free. Blue light filtering sharpens details and contrast is greatly improved.

- 08530** Aviator style
 - 08531** California Beach
 - 08532** Clip-On style
- Prescription glasses available on special order

DRIVING GOGGLES

Great for off-road, nostalgia drags and sand dune racers, plus anyone who is concerned with optimum eye protection. These metal frame, shatter proof clear or smoked glass goggles are available for a variety of racing applications.



- 08510** Goggles, clear Climax® CL510
- 08510.LENS** Goggles, clear lenses only, CL510
- 08510.SMK** Goggles, smoked Climax®, CL510
- 08510.SMKLENS** Goggles, smoked lenses only, CL510
- 08520** Bubble Goggles (Not shown)



JACKETS

Deist Jackets available for all seasons. Summer, Winter, or just because you need a jacket. Available in sizes from Small to XXL.

- 02400.S** Summer Jacket
- 02400.W** Nylon Winter Jacket
- 02400.LT** Lightweight cotton Jacket

CUSTOM JACKETS AVAILABLE

Design your own or let our design team assist you with your specific jacket needs!



35th ANNIVERSARY

This T-Shirt is truly a collectors item. Available in sizes from Small to XXL.

- 02535** Deist 35th Anniversary



DEIST #1 SHIRT

With one of these multi-colored Deist T-shirts we guarantee you will be a part of the "COOL CROWD" at the races or on the street. Available in sizes from Small to XXL.

- 02500** Deist "T" Shirts

CREW APRONS

When working around race cars, nothing protects you and the car, like an apron. Available in fire retardant, or cotton/polyester material. A must in outfitting the professional crew. All crew aprons come with two pockets except -re-fueler.

- 02800** Fire retardant crew Black, Red or Blue
- 02900** Cotton/Polyester crew Black, Red or Blue.
- 80224** Re-Fueler Apron crew (Silver)



THE DEIST MODEL "A" STREET ROD FIRE TRUCK

Lockable Coin Bank, Limited Edition, 1/25 Scale.



Part No. Deist Truck

10.



YOUR LOGO EMBROIDERED AT ADDITIONAL COST

Order Line: (800) 383-3478 | Tech Line: (818) 240-7866 | Fax Line: (818) 244-9230

STANDARD QUICK RELEASE SYSTEMS

The quick release system is designed for ease of entry and exit. Just snap in the lap belt and shoulder harness ends. To release belts simply twist the knob.

2" STANDARD QUICK RELEASE LAP BELTS

Two inch webbing, quick release lugs and your choice of mounting. All are standard draw and are adjustable from 28" to 55" between lap belt mounting points.

562100 2" Q/R Lap Belts, Bolt-In

562200 2" Q/R Lap Belts, Snap-In

562300 2" Q/R Lap Belts, Wrap Around.



STANDARD QUICK RELEASE BUCKLE & CROTCH STRAP ASSEMBLIES

Features a forged aluminum buckle assembly, a leather pad and your choice of crotch straps. Easy to operate, simply rotate left or right to release. The 5-point set up is anchored in front, the 6-point type crotch strap is used in place of a 5-point when a driveshaft or any other obstacle prevents straight-down mounting (it straddles the tunnel). The 7-point is a true anti-submarine setup as each side strap goes underneath the thigh and attaches to the same point as the lap belt. The center strap mounts directly in front of the seat to the floor.

560305 5-Point Quick Release Buckle W/Crotch Straps

560306 6-Point Quick Release Buckle W/Crotch Straps

560307 7-Point Quick Release Buckle W/Crotch Straps

3" STANDARD QUICK RELEASE LAP BELTS

Three inch webbing, quick release lugs and your choice of mounting. All are standard draw and are adjustable from 28" to 55" between lap belt mounting points.

563100 3" Q/R Lap-Belts, Bolt In

563200 3" Q/R Lap-Belts, Snap-In

563300 3" Q/R Lap-Belts, Wrap-Around

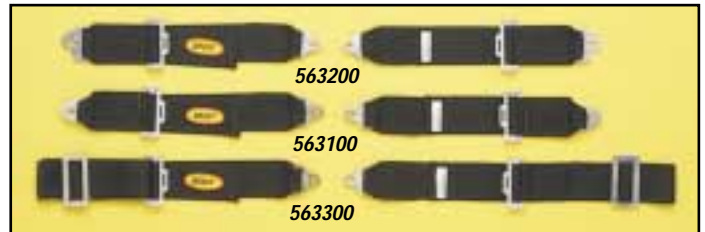

FIRE PROTECTIVE 5 POINT SEAT BELT

This setup is used primarily in drag racing applications where the driver is exposed to fire hazards. It includes a 5-point crotch strap assembly.

563365.FC Top Fuel 5 Point



Quick Release 5-Point Seat Belt Part Numbers

Quick Release Lap Belt	Quick Release Shoulder Harness			
	V-Style	Y-Style	Twin	Loop
	573110	573320	573330	573360
563100	563115	563125	563135	563165
563200	563215	563225	563235	563265
563300	563315	563325	563335	563365



BELTS & HARNESSSES



QUICK RELEASE SYSTEMS

The quick release system is designed for ease of entry and exit. Just snap in the lap belt and shoulder harness ends. To release belts simply twist the knob.



583125
Compact Quick Release Belt Assembly
3" Bolt-In Lap Belt
3" Y Style Shoulder Harness

2" COMPACT QUICK RELEASE LAP BELTS

Two inch webbing, quick release lugs and your choice of mounting. All are standard draw and are adjustable from 28" to 55" between lap belt mounting points.

- 582100 2" Compact Q/R Lap Belts, Bolt-In
- 582200 2" Compact Q/R Lap Belts, Snap-In
- 582300 2" Compact Q/R Lap Belts, Wrap Around.



583115
Compact Quick Release Belt Assembly
3" Bolt-In Lap Belt
3" V Style Shoulder Harness

COMPACT QUICK RELEASE BUCKLE & CROTCH STRAP ASSEMBLIES

Features a billet aluminum buckle assembly and your choice of crotch straps. Easy to operate, simply rotate left or right to release. The 5-point set up is anchored in front, the 6-point type crotch strap is used in place of a 5-point when a driveshaft or any other obstacle prevents straight-down mounting (it straddles the tunnel). The 7-point is a true anti-submarine setup as each side strap goes underneath the thigh and attaches to the same point as the lap belt. The center strap mounts directly in front of the seat to the floor.



- 580305 5-Point Quick Release Buckle W/Crotch Straps
- 580306 6-Point Quick Release Buckle W/Crotch Straps
- 580307 7-Point Quick Release Buckle W/Crotch Straps

3" COMPACT QUICK RELEASE LAP BELTS

Three inch webbing, quick release lugs and your choice of mounting. All are standard draw and are adjustable from 28" to 55" between lap belt mounting points.

- 583100 3" Q/R Lap-Belts, Bolt In
- 583200 3" Q/R Lap-Belts, Snap-In
- 583300 3" Q/R Lap-Belts, Wrap-Around



583135
Compact Quick Release Belt Assembly
3" Bolt-In Lap Belt
3" Twin Style Shoulder Harness

Quick Release 5-Point Seat Belt Part Numbers

Quick Release Lap Belt	Quick Release Shoulder Harness			
	V-Style	Y-Style	Twin	Loop
583100	583115	583125	583135	583165
583200	583215	583225	583235	583265
583300	583315	583325	583335	583365

FIRE PROTECTIVE 5 POINT SEAT BELT (Not shown)

This setup is used primarily in drag racing applications where the driver is exposed to fire hazards. It includes a 5-point crotch strap assembly.

- 583365.FC Top Fuel 5 Point



Order Line: (800) 383-3478 | Tech Line: (818) 240-7866 | Fax Line: (818) 244-9230

LAP BELT & HARNESS MOUNTING HARDWARE

Because mounting hardware can be the weak link in any belt/harness installation, Deist has put a major emphasis on these components. Snap-in and bolt-in belt ends and the 3-bar adjusters for wrap-around mounting are manufactured exclusively for and by Deist. You're better off with Deist quality hardware!

60000 Flat snap and eyebolt kit: Includes: 1 each-flat snap, 7/16-20 X 1-1/4" eye bolt, 2-1/4" flat washer, lock washer & nut.

60000.1 Eyebolt Only 7/16-20 X 1-1/4"

60000.2 Eyebolt Only 7/16-20 X 2"

60001 Eyebolt Kit: Includes: 7/16-20 X 1-1/4" Eyebolt, Washer, Lock Washer and Nut.

60002 90° Snap & Eyebolt Kit: Includes: 1 each forged 90° snap, 7/16-20 X 1-1/4" eyebolt, flat washer, lock washer and nut.

60003 Floor Mount Kit; Used to convert wrap-around belts to bolt-in mounting, Includes: 1 each mounting tab, bolt, 7/16-20 X 1-1/4" nut, flat and lock washers.

60274 Heavy duty 3 bar slide adjuster, for 2" webbing.

60374 Heavy duty 3 bar slide adjuster, for 3" webbing.

60400 VW adapter 24mm to 7/16-20

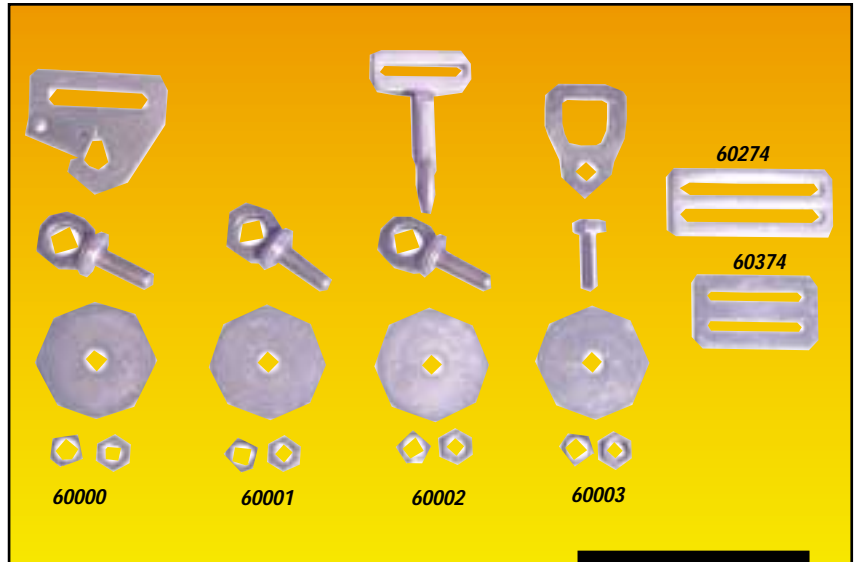

60000

60001

60002

60003

60274

60374



VW Adapter

60400

OPTIONAL EQUIPMENT FOR SEAT BELTS

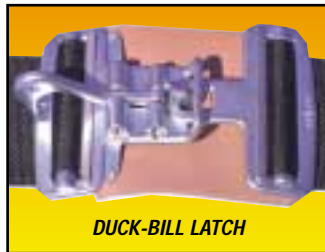

DUCK-BILL LATCH

HIGH VIBRATION ADJUSTER SPRINGS

To guard against lap belts or shoulder harnesses loosening in competition, Deist offers special adjusters that prevent loosening of webbing due to high vibration. These adjusters are available for all 3" and 2" lap belts, shoulder harness and 5 point systems. **Add .5 to the part number for high vibration springs added to adjusters.**



70311

installed option on all 3" shoulder harnesses. **Also available as a slip-on accessory for any 2" and 3" shoulder harness.**

70200 2" Slip-On Nylon (pair)

70201 2" Sewn-On S/H Nylon (pair)

70210 2" Slip-On FR Cotton (pair)

70211 2" Sewn-On S/H FR Cotton (pair)

70300 3" Slip-On Nylon (pair)

70301 3" Sewn-On S/H Nylon (pair)

70310 3" Slip-On FR Cotton (pair)

70311 3" Sewn-On S/H FR Cotton (pair)

SHOULDER PADS

Off Road, Oval Track and Endurance racers appreciate the extra comfort these shoulder pads provide. They are normally a factory-



70200



70310

LAP BELT/SHOULDER HARNESS REBUILDING SERVICE

Many racing organizations have limitations as to the service life of the seat belts. Most require the units to be replaced every 2 years. Deist offers competitors an economical alternative...rewebbing. For a nominal charge, Deist will inspect the hardware and replace the old webbing on the seat belt with new webbing that meets or exceeds Mil-Spec Standards or the commercial equivalent. For latch-type systems, it is a great opportunity to have Deists exclusive Latch-Guard™ installed. (Mandatory for NHRA & IHRA)



BELTS & HARNESSSES

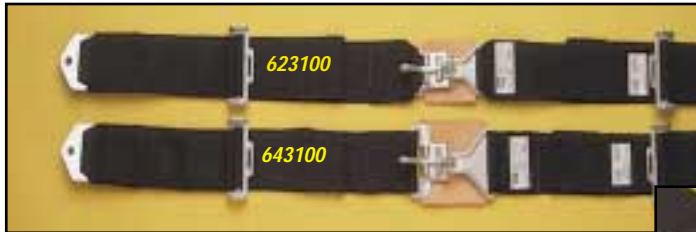

LATCH TYPE LAP BELTS ASSEMBLIES STANDARD LENGTH

Range from 24" to 55" between mounting points.

- 623100** 3" Belt, Standard Bolt-In
- 643100** 3" Belt, Heavy Duty Bolt-In
- 623200** 3" Belt, Standard Snap-In
- 643200** 3" Belt, Heavy Duty Snap-In
- 623300** 3" Belt, Standard Wrap Around
- 643300** 3" Belt, Heavy Duty Wrap Around



SHORT COUPLED

Range from 20" to 45" between mounting points.

- 623100.1** 3" Belt, Standard Bolt-In
- 643100.1** 3" Belt, Heavy Duty Bolt-In
- 623200.1** 3" Belt, Standard Snap-In
- 643200.1** 3" Belt, Heavy Duty Snap-In

Also available in 2" Assemblies.

EXTRA LONG

Range from 35" to 65" between mounting points.

- 623100.3** 3" Belt, Standard, Bolt-In
- 643100.3** 3" Belt, Heavy Duty Bolt-In
- 623200.3** 3" Belt, Standard Snap-In
- 643200.3** 3" Belt, Heavy Duty Snap-In

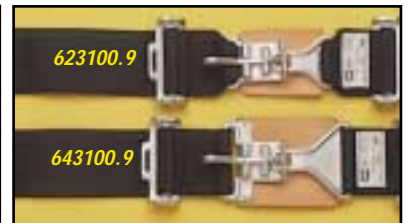

REVERSE DRAW LAP BELTS

Range from 24" to 55" between mounting points.

- 623100.9** 3" Belt, Standard Bolt-In
- 643100.9** 3" Belt, Heavy Duty Bolt-In
- 623200.9** 3" Belt, Standard Snap-In
- 643200.9** 3" Belt, Heavy Duty Snap-In
- 623300.9** 3" Belt, Standard Wrap Around
- 643300.9** 3" Belt, Heavy Duty Wrap



CROTCH STRAPS

- 600305** 2" Crotch strap, 5 pt. wrap around
- 600306** 2" Crotch strap, 6 pt. wrap around
- 600307** 2" Crotch strap, 7 pt. wrap around
- 600308** 2" Crotch strap, 5 pt. floor mount kit
- 600309** 2" Crotch strap, 5 pt. adjustable bolt-in

DUCK-BILL TYPE LAP BELTS

- 653100** 3" Bolt-In Reverse Draw 24"-55"
- 653200** 3" Snap-In Reverse Draw 24"-55"
- 653300** 3" Wrap Arnd. Reverse Draw 24"-55"
- 612100** 2" Bolt-In Reverse Draw 24"-55"
- 612200** 2" Snap-In Reverse Draw 24"-55"
- 612300** 2" Wrap-Arnd. Reverse Draw 24"-55"

Standard Colors, Red, Blue or Black. Custom Colors Gray, Purple, Pink, Orange, Green, Fl. Yel. & Yel. Gold

DUCK-BILL TYPE LAP BELTS

Constantly striving to improve driver safety, the Duck-Bill latch assembly was developed in 1993, incorporating the **Latch-Guard™** concept along with the reverse draw feature.



LATCH GUARD™ / ARM RESTRAINTS

Developed in 1972, Deist arm restraints do an excellent job of restraining a driver's arms inside the cockpit in case of an accident. The arm restraints must be adjusted as short as possible while still allowing free movement of the steering wheel. Deist developed the **Latch-Guard™** in 1981, a simple yet effective device that consists of a strap (which attaches to the latch handle) and Velcro™ closure. The **Latch-Guard™** prevents anything from getting hooked underneath the latch and causing accidental opening. Order the **Latch-Guard™** option with any Deist standard or heavy duty latch style lap belt. Recommended factory installation.



- 60011** Latch Guard (Slip-On)
- 60012** Latch Guard (Factory)
- 60019** Arm Restraint

Order Line: (800) 383-3478 | Tech Line: (818) 240-7866 | Fax Line: (818) 244-9230



SHOULDER HARNESSSES



3" STD QUICK RELEASE	3" COMPACT QUICK RELEASE	V-STYLE DESCRIPTION	3" WEB LATCH TYPE	2" WEB LATCH TYPE
573110	593110	3" V-Style With Bolt-In End	603110	602110
573210	593210	3" V-Style With Snap-In End	603210	602210
70311	70311	Sewn-in Shoulder Pads	70311	70211

Measure approximately 19" from adjuster to mounting point. Use when rollbar crossbrace is directly behind driver's seat (within 1/4" below shoulder line).

3" STD QUICK RELEASE	3" COMPACT QUICK RELEASE	Y-STYLE DESCRIPTION	3" WEB LATCH TYPE	2" WEB LATCH TYPE
573120	593120	3" Y-Style With Bolt-In End	603120	602120
573220	593220	3" Y-Style With Snap-In End	603220	602220
573320	593320	3" Y-Style With Wrap Around End	603320	602320
70311	70311	Sewn-in Shoulder Pads	70311	70211

Use when mounting point to system is between 21"-44" behind the seat, as measured from adjuster on the chest



3" STD QUICK RELEASE	3" COMPACT QUICK RELEASE	TWIN-STYLE DESCRIPTION	3" WEB LATCH TYPE	2" WEB LATCH TYPE
573130	593130	3" Twin With Bolt-In End	603130	602130
573230	593230	3" Twin With Snap-In End	603230	602230
573330	593330	3" Twin With Wrap Around End	603330	602330
70311	70311	Sewn-in Shoulder Pads	70311	70211

The most preferred harness set-up. Use when roll bar crossbrace is located behind the seat (between 12"-30" from adjuster to mounting point) & 1"-4" below shoulder.



3" STD QUICK RELEASE	3" COMPACT QUICK RELEASE	LOOP-STYLE DESCRIPTION	3" WEB LATCH TYPE	2" WEB LATCH TYPE
573360	593360	3" Loop	603360	602360
70311	70311	Sewn in Shoulder Pads	70311	70211

Primarily used in drag racing when harness is looped around roll cage upper frame hoop directly behind the seat. Anchor point is generally 19" from adjuster.



Latch Style 5-Point Seat Belt Part Numbers

Latch Style Lap Belt	"V" Harness	"Y" Harness	"TWIN" Harness	"LOOP" Harness
623100 "B/I"	603110	603320	603330	603360
623200 "S/I"	623115	623125	623135	623165
623300 "W/A"	623215	623225	623235	623265
643100 "B/I"	623315	623325	623335	623365
643200 "S/I"	643115	643125	643135	643165
643300 "W/A"	643215	643225	643235	643265
653100 "B/I"	643315	643325	643335	643365
653200 "S/I"	653115	653125	653135	653165
653300 "W/A"	653215	653225	653235	653265
	653315	653325	653335	653365

**STANDARD
LATCH**

**HEAVY DUTY
LATCH**

**DUCK-BILL
LATCH**

STANDARD BELT ABBREVIATIONS:

"B/I" Bolt-In mounting end fittings, "S/I" Snap-In mounting end fittings, "W/A" Wrap Around mounting end fittings



BELTS & HARNESSSES

FIVE POINT DUCK-BILL® HARNESS SYSTEM

Deist Duck-Bill® was designed in 1993 to prevent inadvertent opening. Drop forged construction and compact integrated latch, link and adjusters for maximum strength and performance.

653115
DUCK-BILL®
Belt Assembly
3" Bolt-In Lap
Belt 3" V Style
Shoulder Harness



643365.FC
**Heavy Duty
Latch Belt Assembly**
3" Wrap Around Lap
Belt 3" Loop Style
Shoulder Harness
with Fire retardant
covering. Recom-
mended for Top
Fuel, Funny
Car, and Alcohol
Drag Racing.



Latch Guard™ not shown
is required by NHRA.
See page 14 for details.



623235
**Standard Latch
Belt Assembly**

3" Bolt-In Lap Belt 3" Twin Style
Shoulder Harness Shown above with the
optional (70311) Sewn-In Shoulder Pads
and (60012) Latch Guard™.



623115
**Standard Latch Belt
Assembly** 3" Bolt-In
Lap Belt 3" V Style
Shoulder Harness

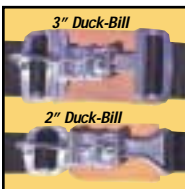

3" Duck-Bill



Standard Latch

Heavy Duty Latch

653125
DUCK-BILL®
Belt Assembly
3" Bolt-In Lap
Belt 3" Y Style
Shoulder Harness

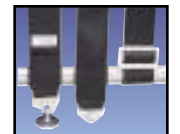

2" Duck-Bill



653300 3" Duck-Bill® Wrap Around Lap Belt

Order Line: (800) 383-3478 | Tech Line: (818) 240-7866 | Fax Line: (818) 244-9230

BELTS & HARNESSSES



623410
 Dune Buggy Belt Assembly. 3" Bolt-In Lap Belt with 3" sewn in V Shoulder Harness and P/N 70301 Pads. Available in Red, Blue or Black.
Custom Colors
 Florescent Yellow, Pink, Orange, Green, Gray or Purple.



BUGGY BELTS

792720
 Economical Buggy Belt Assembly 2" Bolt-In Lap Belt, Automotive-Type Latch with 2" Y Style Loop Shoulder Harness.

792920 2" Y wrap-around harness with loops for lap belt.
792720 2" Lap belt/shoulder harness Buggy Belt assembly

AUTOMOTIVE LAP BELT



629420 Dune Buggy Belt Assembly 3" Bolt-In Lap Belt with sewn in 2" Y Style Shoulder Harness.



792100

792100 2" Automotive-type lap belt, bolt-in, chrome finish
792200 2" Automotive-type lap belt, snap-in, chrome finish



622420 Dune Buggy Belt Assembly 2" Bolt-In Lap Belt with sewn in 2" Y Style Shoulder Harness.



622130. Econo
 Dune Buggy Belt Assembly 2" Bolt-In Lap Belt, No Adjusters with sewn in 2" Twin Style Shoulder Harness.



Automotive 3-Point Lap Belt
792190 2" 3-Point Bolt-In Automotive Lap Belt
792290 2" 3-Point Snap-In Automotive Lap Belt with a Bolt-In Single Shoulder Strap

792290



629430 Dune Buggy Belt Assembly 3" Bolt-In Lap Belt with sewn in 2" Twin Style Shoulder Harness.



629410 Sand Belt Assembly 3" Bolt-In Lap Belt With Sewn-In 2" V Style Shoulder Harness.



622430 Dune Buggy Belt Assembly 2" Bolt-In Lap Belt with sewn in 2" Twin Style Shoulder Harness.



TIE DOWNS & STRAPS



RATCHET TIRE TIE-DOWN
36200 2" In Line Ratchet working load 5,000 lbs. with 8' reach and spring loaded hooks on each end.



RATCHET STRAP/TIRE TIE-DOWN
36201 2" Tire Tie-Down, In Line Ratchet working load 5,000 lbs., has adjustable side straps and spring-loaded hooks on each end.

RATCHET CHASSIS TIE-DOWN

36505 2" Chassis Tie-Down, In Line Ratchet on one end and a frame loop with hook on the other end. Working load 5,000 lbs. with an 8' reach.



RATCHET TIRE TIE-DOWN
36800 2" Tire Tie-Down, twin straps hold upper sides of the tires. Ratchet with snap hooks on both ends. Working load 5,000 lbs. Maximum tire width 8"



TIE-DOWN HARDWARE

36010 Attachment Plate & retractable ring. (Working load 2500 lbs.)

36011 Anchor button with removable retaining ring. (Working load 2000 lbs.)



ANCHOR HARDWARE

36000 Link & U-Bolt Kit. Ideal for trailer floors.

18.



CAR RATCHET KITS

36100.6 4 point ratchet combo kit. Contains 2 each P/N 36200 (6' reach) and 36502

36100.8 4 point ratchet combo kit. Contains 2 each P/N 36200 (8' reach) and 36502

Order Line: (800) 383-3478 | Tech Line: (818) 240-7866 | Fax Line: (818) 244-9230

TIE DOWNS & STRAPS



UTILITY TIE-DOWN
Great for use in race car trailers, off-road vehicles, etc, they are ideally suited for a myriad of purposes...

including securing tool boxes, spare parts, battery boxes, and coolers. The webbing is colorful Polypropylene (1" or 1-1/2" width) and each has a spring loaded adjuster. **Custom colors and lengths available.**

- 40103 Utility Tie-Down Strap, 3' length, 1" webbing
- 40106 Utility Tie-Down Strap, 6' length, 1" webbing
- 40110 Utility Tie-Down Strap, 10' length, 1" webbing
- 40205 Utility Tie-Down Strap, 5' length 1-1/2" webbing
- 40207 Utility Tie-Down Strap, 7' length, 1-1/2" webbing
- 40209 Utility Tie-Down Strap, 9' length, 1-1/2" webbing



TOW STRAPS

Designed for pulling race cars around in the pit area behind tow vehicles, these tow straps come in a variety of different models to suit each particular racing application. Standard colors, Red, Blue or Black. **Custom colors and lengths available...call for details.**

- 41114 14' Tow Strap, 2" webbing, loop on one end, and loop & hook on the other end.
- 41115 14' Tow Strap, 1" webbing, loop and clip on both ends.
- 41120 20' Tow Strap, 2" 10,000 Lb., loop on both ends.
- 41121 20' Tow Strap, 2" 20,000 Lb., loop on both ends

BUMPER STRAPS

Heavy duty reinforced nylon strap that facilitates securing tow strap or winch hook to bumper. Features a special securing pin for through loop attachments.



41403 Bumper Attachment Strap

ATTACHMENT STRAP

36612 1" attachment strap motorcycle 14" With loops (Pr.)



RATCHET TIE-DOWN



36603 1" Mini-Ratchet Tie-Down, light duty, with 6' reach and "S" hooks working load 600 lbs. Standard colors, Red, Blue or Black. **Custom colors and lengths available.**



36604 1" Mini-Ratchet Tie-Down, medium-duty, with 8' reach and "S" hooks, working load 1,200 lbs. Standard colors, Red, Blue or Black. **Custom colors and lengths available.**



36605 1" Motorcycle Cam-Lock Tie-Down 5' Long with "S" hooks, working load 600 lbs. Standard colors, Red, Blue or Black. **Custom colors and lengths available..**

ATTACHMENT STRAPS

Racers can find literally hundreds of uses for these handy devices, which come in a variety of sizes and configurations. They include lengths of heavy-duty nylon webbing with metal links on both ends. (sold in pairs) working load 5000 lbs.

- 36620 2" Attachment Strap, 14" metal links on both ends
- 36621 2" Attachment Strap, 24" metal links on both ends

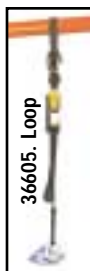

36605. Loop

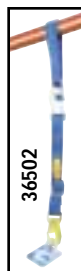

36602



36503

- 36501 2" non adjustable 24" strap with loop & snap on end.
- 36502 2" adjustable 24"-48" strap with loop & snap on end.
- 36503 2" adjustable 12"-27" strap with snaps on both ends.

FRONT CHASSIS ATTACHMENT STRAP



HELMETS



BELL HELMETS

DEIST offers both full face and open face style helmets that provide optimum protection. The most important consideration is that Bell Helmets are built to meet and exceed Snell "SA95" and "SFI131.2" specifications. The "SA" rated helmets have a fire-resistant liner and are engineered to withstand the vibrational and impact forces prevalent in automotive competition, as opposed to the motorcycle "M" rated helmets. Special design features include, extended coverage (EC) foam liners for impact absorption and protection which literally surround your head. All shells are hand laminated thermo-set composites made from various Kevlar®, carbon fiber and fiberglass laminates. All helmets feature Bell's exclusive fire-resistant Durvil® fit pad, proven more comfortable and efficient at wicking away perspiration than Nomex®.

DEIST STOCKS the following Bell Helmets: Mag 4 (15600), Sport II (15400), Sport II Forced Air Fiberglass (15400-FA), M2 (15300), XFM-1(15500), and AFX-1 (15700). Special Order Helmets, SR-PRO, Mag 5, Sport II Forced Air Kevlar®, M3, Vortex Turbo Air, Vortex Turbo Air Drag. All Shields are available in: Clear, Smoke, Dark Smoke, (High Resolution Amber available for some Helmets).

HAT SIZE CONVERSION CHART

To properly determine head circumference, run a soft tape measure around your head (approximately one inch) above the eyebrows and just over the ears.

Hat Size	Head Circum. (Inches)	Head Circum. (Metric)
6-1/2"	21-5/8"	55cm.
7"	22"	56cm.
7-1/8"	22-3/8"	57cm.
7-1/4"	22-3/4"	58cm.
7-3/8"	23-1/8"	59cm.
7-1/2"	23-1/2"	60cm.
7-5/8"	24"	61cm.



HELMET/CHIN RESTRAINT

The tremendous centrifugal forces encountered in oval track racing (especially short tracks) often put a strain on a driver's neck. Significant relief is obtained by using a DEIST Helmet Restraint which serves to "tether" the helmet. Just attach the D-Ring to the helmet, clip on the restraint and loop it under the armpit. A comfortable driver is a better driver!
80204 Helmet Restraint Assembly **80205** Chin To Seatbelt Buckle Restraint Assembly

HANDY ACCESSORIES



15900
NOW AVAILABLE
PART # 15900 OUR
NEW 105 CFM BLOWER
MOTORS



80215

HELMET SUPPORT
 See Page 9
 80213 Full Circle
 80215 Wedge

HELMET SKIRTS

Designed to provide an extra measure of protection. Attaches to the helmet by means of pressure-sensitive fastening band. Available in Knit or Skirt type styles
03000 Knit Nomex® Helmet Skirt
03001 Nomex® Helmet Skirt (Standard White)
 Available in Colors (Special Order)



ON-BOARD FIRE SYSTEMS

ON-BOARD FIRE EXTINGUISHERS

Deist safety offers competitors a choice between two different types of on-board fire extinguishing systems, Halon 1301 and Coldfire 302. When it comes to fire systems, nobody gives you the quality and the options available with Flame Out, a division of Deist Safety.



Cold Fire 302 is a fire suppressing agent for Class B oil/fuel fires. Also suitable for Class wood and paper fires. It suppresses quickly, prevents reflash, is safe to store, handle and use. Leaves virtually no residue and is environmentally safe. On Class B fires, the chemical encapsulates the oil and prevents burning and reignition. Cold Fire 302 has the advantages of foam and dry chemical without the mess. Cold Fire suppressants are UL listed and approved by many state agencies.

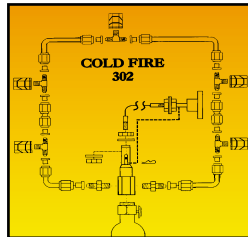

Our Halon 1301 Systems, which utilize lightweight 6061-T6 aluminum bottles, is ideal for the weight conscious racer. When the FE-1301 is spent a fully charged replacement cartridge can easily be installed. The system comes in 5 and 10 pound sizes. You have a choice of three actuating valves (direct, remote with cable and Pneumatic). Systems come with a standard 3' release cable (6', 9' and custom length cables are also available).

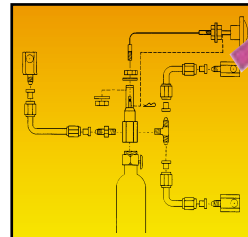

100% Environmentally Safe... 100% Biodegradable!

Cold Fire 302 is a harmless plant and water based agent. It may cause dryness of the skin, and may irritate the eyes if sprayed directly into them. This product is not combustible and has a pH of 7.5, Toxicity is negligible.

HALON 1301 SYSTEMS

- 89005** 5 lb. System (3' release)
- 89010** 10 lb. System (3' release)
- 89105** 5 lb. Cartridge (4 X 14 5/8)
- 89110** 10 lb. Cartridge (5.25 X 18 5/8)
- 90502** 5 lb. Steel Bottle (5-3/8 X 12)

COLD FIRE SYSTEMS

- 91302** 12 oz. Hand Held Fire Ext.
- 91302.HOL** Holster for above
- 91205** 5 lb. System (3' cable)
- 91205.CAR** 5 lb. Cartridge
- 91310** 10 lb. System (3' cable)
- 91310.CAR** 10 lb. Cartridge
- 91319** Nozzle 302 Female 1/8" NPT
- 91319.T** Tee for above (1/8" NPT to AN-4)
- 91320** Nozzle 302 Male AN-4
- 91320.T** Tee for above (Male AN-4)



SYSTEM ACCESSORIES

- 89203** 3' Release cable
- 89206** 6' Release cable
- 89209** 9' Release cable
- 89251** Injector Head with knob
- 89252** Injector Head with bracket
- 89260** 3/8" Mounting bracket 5 lb. bottle
- 89265** 3/8" Mounting bracket 10 lb. bottle
- 89400** Pneumatic Actuated Injector

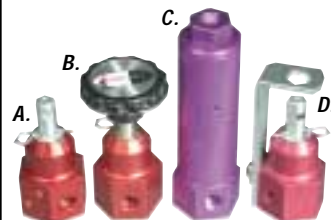

- A. 89250**
- B. 89251**
- C. 89400**
- D. 89252**



Order Line: (800) 383-3478 | Tech Line: (818) 240-7866 | Fax Line: (818) 244-9230

TRANSMISSION BLANKETS

TRANSMISSION BLANKETS

Multiple layers of "ballistic" material are used to capture exploding shrapnel. These blankets meet or exceed SFI 4-1 Specs. Features include: water and oil-resistant nylon covering and heavy-duty adjustable straps. OEM-type transmission blankets are equipped with positioning straps with metal tabs.



81020



81535



81124



81012



81126



Lenco New Generation & Small New Generation blankets are available on request.

NOTE: Blankets also available for other transmissions manufactured by B & J, Owens, Skiddoo and Marine Turbines. **Custom blankets can be manufactured for most other applications.**

LOWER ENGINE CONTAINMENT DEVICE

82010 Soft Kevlar® Diaper attaches to engine block with adjustable quick release buckles.

82020 Hard resin Diaper constructed of carbon fiber and Kevlar®, attaches to frame rail or engine block with adjustable quick release buckles. Optional: High resilience rubber inlay re-establishes the oil boundary in case the carbon fiber has been penetrated. Exceeds SFI 7.1 specifications.



82010

80210.ABS Diaper absorbent pads Available in 1, 5 & 10 pair packs.



82020

22.



Order Line: (800) 383-3478 | Tech Line: (818) 240-7866 | Fax Line: (818) 244-9230



BLOWER RESTRAINTS

DEIST Blower Restraints are designed to meet SFI Specifications for use on Super-Charged Racing Engines running alcohol and/or nitromethane fuel mixtures. Fits 4-71 through 14-71 type blowers.



A. 14-1000
14-71 Blower
Large Opening

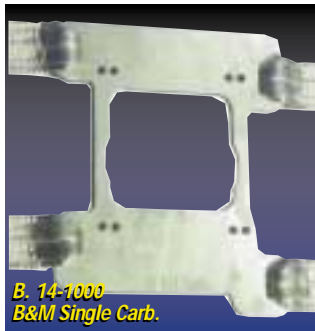

B. 14-1000
B&M Single Carb.

14-1000 Blower Restraint Plate Straps (SFI 14-1) (Complete) Available For the Following; B&M Single Carburetor, B&M Dual Carburetor, Dual Carburetor Adapter, GMC 4-71 Blower, 6-71 to 12-71 Blowers With Bird Catcher, 6-71 To 12-71 Blowers With Buzzard Catcher, 14-71 Blower With Buzzard Catcher. Special Custom Designs Available.

14-1100 Blower Restraint Plate (SFI 14-1) (No Hardware)

14-1500 Hardware Set (SFI 14-1) 4 ea. (paddle, clips & pin)

14-1510 Hardware Each (SFI 14-1) 1 ea. (paddle, clips & pin)

14-2000 Blower Restraint and Bag (SFI 14-2) (Complete) Available For the Following; All Manufacturers 8-71 To 14-71 Both 2-Gear and 4-Gear Units.

14-2100 Blower Restraint and Bag (SFI 14-2) (No Hardware)

14-2210 Blower Restraint (SFI 14-2) (No Bag No Hardware)

14-2200 Kevlar® Bag Only (SFI 14-2)

14-2500 Hardware Set (SFI 14-2) 5 ea. (paddle, clips & pin)

14-2510 Hardware Each (SFI 14-2) 1 ea. (paddle, clips & pin)

14-2000.BOAT Blower Restraint and Bag For Drag Boat Racing (SFI 14-2) (Complete, Not Shown)

14-2000.PSI P.S.I. Screw Blower Restraint and Bag (SFI 14-21) (Complete, Not Shown)

14-2000.WHP Whipple Screw Blower Restraint and Bag (SFI 14-21) (Complete, Not Shown)

14-3000 Blower Restraint and Bag (SFI 14-3) Available For the Following; All Manufacturers 8-71 To 14-71 Both 2-Gear and 4-Gear Units.

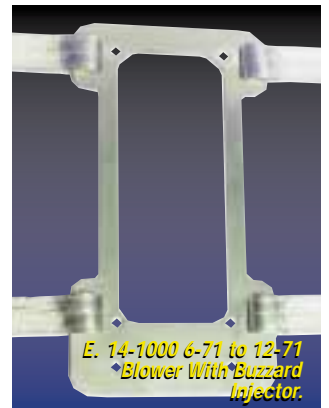

E. 14-1000 6-71 to 12-71
Blower With Buzzard
Injector.

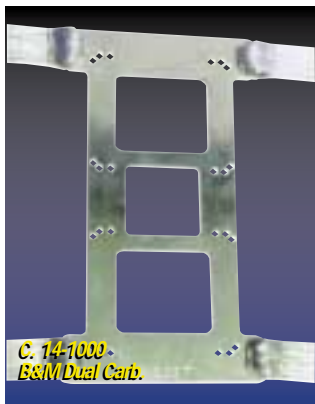

C. 14-1000
B&M Dual Carb.



F. 14-1000 6-71 to 12-71
Blower With Small
Opening.

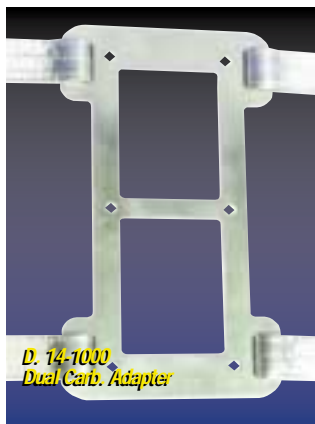

D. 14-1000
Dual Carb. Adapter

Necessary Information Required

Engine Specifications:

Cylinder Heads:

Blower Manifold:

Blower Type:

Injector Type:

Mfg. Make & Model

Mfg. Make & Model

Mfg. Make & Model

Mfg. Make & Model

Mfg. Make & Model

Distance between injector bolts and exhaust header bolts



G. 14-2000 14-71
4-Gear Blower.



FUEL CELLS, JUGS & ACCESSORIES



These rugged one piece seamless molded cells come with a special anti-slosh foam baffling that is impervious to fuel and racing gasoline, as well as all known fuel additives. They are designed not to rupture on impact and to retain fuel even if vehicle overturns. Fuel cells are equipped with aircraft-style filler neck and AN-8 fittings. They are accepted by NHRA, IHRA, NASCAR, SCORE, HDRA, SCCA, IMSA and other racing organizations.

- 91401.....1-gallon Fuel Cell (6" X 6" X 12")
- 91403.....3-gallon Fuel Cell (8" X 8" X 14-1/2")
- 91404.....4-gallon Fuel Cell (8-3/4" X 8-3/4" X 17-3/4")
- 91405.....5-gallon Fuel Cell (13" X 13" X 8")
- 91408.....8-gallon Fuel Cell (20" X 15" X 7-1/2")
- 91412.CT.....12-gallon Circle Track Fuel Cell (20" X 17" X 9")
- 91412.DR.....12-gallon Drag Racing Fuel Cell (20" X 17" X 9")
- 91415.....15-gal. Horizontal Fuel Cell (25" X 17" X 9")
- 91422.....22-gallon Horizontal Fuel Cell (22" X 17" X 9")
- 91432.....32-gallon Horizontal Fuel Cell (25" X 17" X 18")

NOTE: Dimensions listed: length x width x height. Custom metal containment tanks are available by special-order. Please call for details.

DUMP/FUEL CANS

Excellent for storing racing fuel. Designed for re-fueling a race car with maximum efficiency. Handle serves as a vent tube. Gallon markers molded into the jug facilitate keeping track of remaining fuel.

- 91506 6-gallon Dump Can with caps
- 91511 11-gallon Dump Can with caps



ENGINE SLINGS

Deist makes it easy to lift engines in and out of race car chassis, cars, trucks or boats with these heavy-duty engine slings. They loop underneath the headers and are long enough to clear supercharged or fuel injected engines. Won't damage polished aluminum or chrome parts like chains would! **Special colors available on request.**

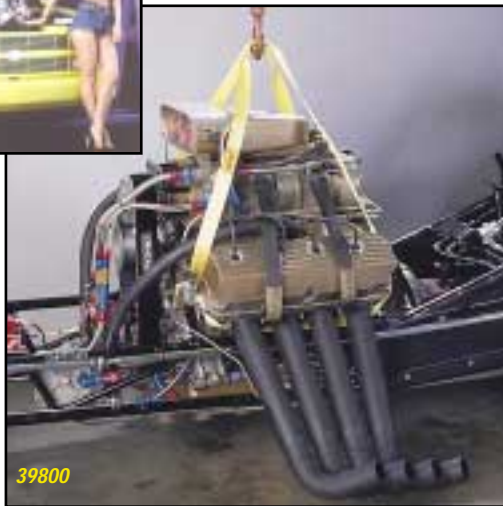

- 39800 Engine Sling Working load 3000 lb (pair) Black. (Cradles engine headers)
- 39801 Engine Lifting Strap Working load 3000 lb Black. (30" straps: Bolt to heads)

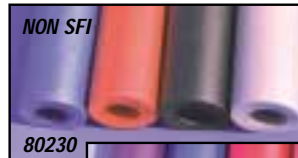

ROLL BAR PADDING

This high impact, high density roll bar padding will keep you protected on the race track.

Available in SFI & non SFI. The SFI rated roll bar padding meets the fire resistant SFI 45-1 Specification.

- 80230 3' Non-SFI Red, Blue, Black, Gray, Yellow or Orange for 1-3/4" tubing.
- 80330 3' SFI Red, Blue, Black or Gray for 1.625-2" tubing.
- 80340 3' SFI Red, Blue, Black or Gray for 1.125-1.5" tubing.



HI-BACK SEATS

Popular in many forms of competition, it features double wall space-age Poly construction and a contoured design for maximum comfort. The seat has openings for the lap belts. Base has six mounting bosses to facilitate easy installation.

- 80400 Seat with upholstery.
- 80401 Seat only.

See page 31 for aluminum seats.

24.



Order Line: (800) 383-3478 | Tech Line: (818) 240-7866 | Fax Line: (818) 244-9230

DRAG CHUTES

Deist pioneered the use of drag chutes over 40 years ago and in the ensuing time has engineered special systems for virtually every Land Speed Record vehicle ever built. That is because there is no firm that can come close to matching the technical expertise of Deist. This same "know-how" and engineering excellence is reflected in each and every drag chute manufactured by Deist. Nobody has more experience in **STOPPING** race cars than Deist! If one of the many standard chutes do not conform to your requirements, please contact the factory for technical assistance.

PILOT CHUTES

Rated the most effective chute on the market by many top racers. Specially designed coil-spring provides consistent opening with outstanding reliability. You can see and feel the difference in a Deist Pilot Chute.

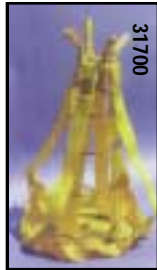

31350 Pilot Chute, 3-1/2" Dia. for 27129.

31400 Pilot Chute, 4" Dia. for 27252.

31600 Pilot Chute, 6" Diameter.

31700 Pilot Chute, 7" Diameter

31700-BOAT Pilot Chute (Boat), 7" Dia. Reinforced with Covered Spring. Ballistic top cover.

31800 Heavy Duty Pilot Chute, 8" Dia.

31810 Heavy Duty Pilot Chute With Pre-Loaded Pilot



CHUTE PACKS

Easily in a class by themselves. Deist Chute Packs feature aluminum trays, shroud-line separators and elastic pack tensioners. Available in 5" X 5", 7" X 7" or 9" X 9" sizes. Choices include a fire-resistant aluminized material (silver), or heavy-duty nylon in your choice of Black, Red, Yellow or Blue.

Silver Pack

30300 Silver Chute Pack, (Specify Height), 9" X 9" Base

30300-KEV Kevlar® Silver Chute Pack, (Specify Height), 9" X 9" Base

Nylon Pack

30200 Pack Pre-Load, 9" X 9" With Deployment Bag

30450 Chute Pack, (Specify Height), 5" X 5" Base

30470 Chute Pack, (Specify Height), 7" X 7" Base

30490 Chute Pack, (Specify Height), 9" X 9" Base

30500 Accessory Kit, Rubber Bands, etc.



DRAG CHUTES

Deist is credited with developing the sport's first drag chutes back in the late 50's. We have maintained a position of leadership to this day. Deist Chutes have always employed the latest state-of-the-art materials and technology. No wonder the majority of drag racing "fast guys" put their trust in Deist Drag Chutes! **(Deist also makes special-order chutes for virtually any application).**

27129 8' Chute, Junior Dragster (5" X 5" Pack).

27225 12' Chute, used for Motorcycle or Snowmobile .

27252 12' Super Quad Chute (7 X 7 Pack).

Super Comp Dragster, up to 180 mph

Super Gas-S/C Full Body Cars up to 160 mph

22554 12' Chute, Dual chutes required on Pro Mods. (Each)

27369 14' Chute, Used for Super Gas Or Super Comp Type Cars (2,000 To 3,000 lbs.) up to 150 mph . Also Suited to 1/8-Mile Applications.

27369.Silver 27369 with silver pack & silver line sleeve.

24564 14' Chute, Used for Pro Stocks.

24564.Silver Dual chutes required for T/F Dragsters. (Each) 24564 with silver pack & silver line sleeve.

25377 15' Chute, Used for Top Alcohol Dragsters and Alcohol Funny Cars Rated To 280 mph. Silver pack & silver line sleeve.

25581 15' Chute, Used for Top Fuel Dragsters and Funny Cars Rated To 310 mph. Silver pack & silver line sleeve.



CHUTE ACCESSORIES

30003 Bridle Line 3' for Pilot Chute.

30003.5 Bridle Line 5' for Pilot Chute.

30003.9 Bridle Line 9' for Pilot Chute.

30022 Release Cable Assembly, 13' (Lever Or Ring)

30023 Release Clip, Attaches 3/8" Cable To Pack

30100 4' Silver Sleeve for Top Fuel and Alcohol Cars



TOP FUEL SUITS & ACCESSORIES

When it comes to Top Fuel, Deist's driving suits and accessories are made to meet or exceed the standard ratings of SFI specifications. Our suits and accessories are manufactured to meet SFI 3-2A/20 and 3.3/20 specifications.

3-3/20 FUEL BOOTS

Similar in construction to the 3-2A/20 Fuel Suit, these boots also feature a hand sewn moccasin-style sole for extra durability and pedal control. Other features include heavy-duty zippers, flap and calf extension. Available in Red, Blue or Black, Other colors available upon request, call for details. **Please state exact shoe size and if intending to be worn with or without inner shoes.**



84400 3-3/20 Fuel and Funny Car Boots

3-3/20 FUEL GLOVES

There is nothing better on the market than Deist's super effective 3-3/20 Fuel Gloves. They feature multiple layers of Nomex® material along with Deist's exclusive "Liquid Barrier" insulation. Full length gripping ribs for optimum driving control and extended gauntlet make up the unique design. These gloves are available in Small, Medium, Large and Extra Large sizes and come in colors of Red, Blue or Black. **Other colors available upon request, call for details.**



84600 Top Fuel and Funny Car

Note: Optional sewn-in Arm Restraints are available.

TOP FUEL FIRE PROTECTION ACCESSORIES

85100 Computer cable cover. Protect the high cost of computer cables with this affordable cover. (Standard 4') **Also available in any length or colors.**



85200 Doghouse clutch can cover. Superior seal between funny car body, and clutch cover doghouse. Eliminates rubbing by the body. The Nomex® material seal reduces fire penetration. **Available in colors or silver.**



85300 Spark plug wire cover. Protects the spark plug wires from fire damages when the burst disk blows. **Available in colors or silver.**

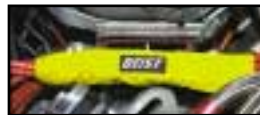

85400 Fuel flow meter cover. **Available in colors or silver.**



26.



3-2A/20 TOP FUEL SUITS

Drivers of Nitromethane burning race cars will appreciate the high standard of quality Deist puts into each 3-2A/20 Fuel Suit. The features include; Multiple layers of Nomex® and special insulation for protection that far exceed existing requirements.

Deist maintains what is probably the industry's most comprehensive testing facility for safety equipment, to ensure the continued outstanding performance of their products. **Special combinations of colors, trims and embroidery are available upon request.**

SFI 3-2A/15 Fuel Suits (Dragsters)

84100.3 3-2A/15 Fuel Suit (1-Piece) Tailored

84100.5 3-2A/15 Fuel Suit (2-Piece) Tailored

SFI 3-2A/20 Fuel Suits (Funny Car)

84200.2 3-2A/20 Standard Fuel Suit (S,M,L & XL)

84200.3 3-2A/20 Fuel Suit (1-Piece) Tailored

84200.5 3-2A/20 Fuel Suit (2-Piece) Tailored

HELMET SUPPORTS

80215 (Wedge) or **80213** (Full circle)

See Page 9



NOSTALGIA TOP FUEL MASK

The nostalgia fuel mask features multiple layers of aluminized silver or Nomex® material with Deist's exclusive "Liquid Barrier" insulation. Includes respirators for the removal of fuel fumes. **Call For Details.**

83110 Top Fuel / Funny Car (Black)

83110.S Top Fuel / Funny Car (Silver)



Order Line: (800) 383-3478 | Tech Line: (818) 240-7866 | Fax Line: (818) 244-9230

MARINE



AQUA VEST

A highly refined vest for boat racing safety. Features a dense, compact flotation material that is about 1/3 the bulk of conventional vests. Also has an improved harness assembly for increased driver mobility and is designed to facilitate the feet-first water entry in case of an accident. Available with or without personal body chute.

- 29100 Aqua Vest
- 29200 Aqua Vest with body chute



BLOWER RESTRAINTS

- 14-1000 Restraint for Gas & Alky (SFI 14-1)
- 14-2000. BOAT Restraint for Top Fuel (SFI 14-2)

See page 23 for more details. Restraints available for Whipple & PSI Screw Blowers.



AQUA SUIT

The Aqua Suit was developed to combine the Aqua Vest with the Ballistic Shorts. The rugged ballistic material used will reduce the damage caused by sharp objects as well as provide necessary flotation.

- 29501 Aqua Suit (Small, Medium, Large & X-Lg)

HELMET RESTRAINT (Not Shown)

The tremendous centrifugal forces encountered in a boat crash can put a strain on a driver's neck. The 3" webbing Chest band is closed with Velcro. Then the D-Rings are attached to the Helmet, 2 in back, 1 on each side & 1 in the front.

- 29600 Helmet Restraint (Small, Medium, Large & X-Lg)

BELTS & HARNESSES

Deist has many styles of seatbelts available. For more details see the following pages.

- Quick Release page 11.
- Compact Quick Release page 12
- Latch Style page 13-16.
- Duck-Bill Style page 13-16.

Custom Ratchets can be attached to provide extra tension if needed to the Lap Belts ONLY.



BOAT CHUTES

Deist is credited with developing the first boat drag chutes in the late 60's. We have maintained a position of leadership to this date. Deist Chutes have always employed the latest state-of-the-art materials and technology. No wonder the majority of the boat drag racing "fast guys" put their trust in Deist Boat Drag Chutes.

See page 25 for more details.

- 28525 12' Boat Chute for Gas & Alky boats up to 200 mph
- 28537 12' Boat Chute for Gas & Alky boats up to 170 mph
- 28525. T/F 12' Boat Chute for Top Fuel boats up to 240 mph
- 28537. T/F 12' Boat Chute for Top Fuel boats up to 220 mph

BALLISTIC SHORTS

You really don't want to know what it feels like to hit the water at a high rate of speed. Just imagine how painful it is to certain parts of the body! That's why Deist offers these super strong shorts made out of the same ballistic nylon as our transmission blankets & blower restraints. Also features elastic side for more comfort.

- 29300 Ballistic Shorts (Small, Medium, Large & X-Lg)



JR. DRAGSTER

DRIVING SUIT

Deist Safety driving suits are manufactured to meet SFI specifications. **See Pages 3 thru 10 for more details.**

00300 Series for one piece suit



06000

MID-TOP DRIVING BOOT

Deist Safety now offers the ultimate in safety, comfort and style! Features Include: Padded Kevlar® Inner Liner and a Non-Skid Rubber Sole. **See Page 8 for more details.** Available in Men's size 6 to 13 in half sizes. Black, Red, Gray or Blue.

06000 Driving Boots SFI 3.3-5



EQUIPMENT BAGS

Protect your valuable safety equipment with matching gear bags. Standard color Black. Custom colors may be ordered. **See page 9 for more details.**

08695 Helmet Bag (16"x16"x10")

08691 Racer Bag (8.5"x25.5"x11.5")

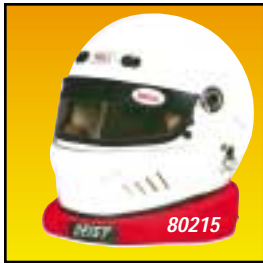

HELMET SUPPORT

Used to support the weight of the helmet, thereby reducing neck fatigue.

See Page 9 for more details.

80215 Wedge shape

DRIVING GLOVES

Knit Nomex® back with leather palm. Available in choices of Red, Blue, or Black. Custom colors available by special order. **See Page 8 for more details.**

04100 Single-Layer Nomex® Glove Leather Palm



04100



81400

BALLISTIC COVER

Multiple layers of "ballistic" material are used to capture exploding shrapnel. Features include: water and oil-resistant nylon covering and heavy-duty adjustable straps. **See page 22 for more details.**

81400 Briggs & Stratton 5hp Ballistic cover



41115

TOW STRAPS

Designed for pulling race cars around in the pit area behind tow vehicles. Standard colors, Red, Blue or Black. **See page 19 for more details.**

41115 14' Tow Strap, 1" webbing, loop and clip on both ends.

DUCK-BILL TYPE LAP BELTS

Constantly striving to improve driver safety, the Duck-Bill latch assembly was developed in 1993, incorporating the Latch-Guard™ concept along with the reverse draw feature. **See pages 11 thru 16 for more details.**

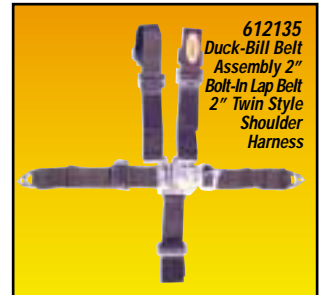

612135 Duck-Bill Belt Assembly 2" Bolt-In Lap Belt 2" Twin Style Shoulder Harness



60019

ARM RESTRAINTS

Arm restraints do an excellent job of restraining a driver's arms inside the cockpit in case of an accident. The restraints must be adjusted as short as possible but, still allow free movement with the steering wheel. **See Page 14 for more details.**

60019 Arm restraint



27129

DRAG CHUTES

Deist is credited with developing the sport's first drag chutes back in the late 50's. We have maintained a position of leadership

to this day. Deist Chutes have always employed the latest state-of-the-art materials and technology. **See page 25 for more details.**

27129 8' Chute, Junior Dragster (5" X 5" Pack).



Order Line: (800) 383-3478 | Tech Line: (818) 240-7866 | Fax Line: (818) 244-9230

SPRINT & KARTING



DOUBLE LAYER ANTRON/NYLON WITH COTTON LINER DRIVING SUITS

These two layer driving suits made from Dupont® 400 denier Antron/Nylon with Cotton liners are available in a one piece design. Deist's one piece suit features the "Action Back" with elastic waistband, knit nylon wrist and ankle cuffs. Standard with knee pads, elbow pads and front pants pockets. Machine washable. Standard sizes: Small, Medium, Large and Extra Large. Colors: Red, Blue or Black. Custom colors available at an additional charge.

00100.2 Standard 2 layer one piece suit

00100.6 Tailored 2 layer one piece suit

For suit size chart refer to page 3.



CUSTOM TAILORED AND SPECIAL COLOR DRIVING SUITS

Custom Antron, Nylon, Indura®, or Nomex® driving suits. One piece and two piece available in a wide array of color choices. Design your own, or let our design team assist you. See Page 6 for more details.



09000

RIB PROTECTOR

The rib protector contains two layers of ballistic material, one layer of high density foam to absorb the energy from impact and a 1/16" thick lexan layer for protection against piercing or blunt objects. Standard sizes: Small, Medium, Large, Extra Large. Stocking Colors: Red, Blue or Black.

09000 Rib Protector.

THREE LAYER NOMEX® / KYNOL® / NOMEX® JACKETS / PANTS / DRIVING SUITS

Three layer Nomex®-Kynol®-Nomex® driving suits provide approximately 500% more protection than single layer suits. Standard sizes: Small, Medium, Large and Extra Large. Stocking Colors: Red, Blue or Black. See pages 3 thru 11 for more details.

DOUBLE LAYER NOMEX® / KEVLAR® JACKETS / PANTS DRIVING SUITS

Two layer Nomex® Kevlar®, driving suits are available in a one piece design or separate jacket and pants combination. See pages 3 thru 11 for more details.



NOMEX SUITS

ADDITIONAL OPTIONS AVAILABLE ON CUSTOM KART SUITS

1. Soft Collar/Shirt Collar
2. Full Circle Stretch Sleeve
3. Action Back
4. Wedge Stretch Sleeve
5. External Heat Shield
6. Groin Breather Panel
7. Boot Cut (straight leg cuffs)
8. Zipper Jacket Pockets
9. Zipper Pants Back Pockets
10. Kool Pockets See Page 7 for more details.
11. Hip Pads
12. Box Quilts
13. 3-Point Epaulet (box sleeve only)
14. Contrasting Thread
15. Knit Lower Back Panel
16. XXL & Larger Sizes

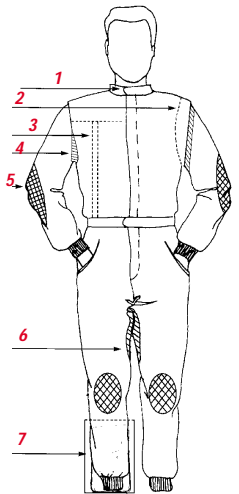

00200

SINGLE LAYER FIRE RETARDANT COTTON JACKETS / PANTS DRIVING SUITS

These single-layer driving suits made from 10-12 oz Indura® Fire Retardant Cotton are available in a one piece design or a separate jacket and pants combination. Deist's one piece suit features the "Action Back" with elastic waistband, Nomex® wrist and ankle cuffs and two way Nomex® zipper with pressure sensitive fastener neck closure and two pant pockets. Machine washable. See Page 4 for more details.

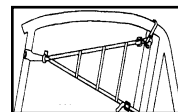

35250

ROLL CAGE NETS

- 35200 Two strap cam buckle
- 35250 Two strap over-center-buckle
- 35300 Three strap over-center-buckle

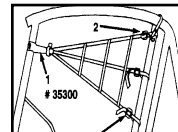

TORQUE TUBE RESTRAINT (Not Shown)

- 35800 Restraint for Torque tubes.



29.

Order Line: (800) 383-3478 | Tech Line: (818) 240-7866 | Fax Line: (818) 244-9230

OFF-ROAD

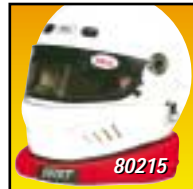

HELMET SUPPORT

Used to support the weight of the helmet, thereby reducing neck fatigue. **See Page 9 for more details.**

- 80213** Full circle 3" thick (Nomex® cover).
- 80215** Wedge shape (Nomex® cover).
- 80220** Horse collar (Nylon cover).
- 80221** Horse collar (Nomex® cover).

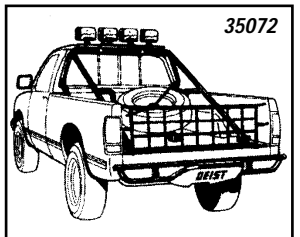
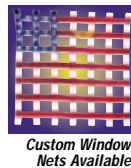

TAILGATE NETS

Improves performance and economy by replacing a solid "air dam" with an aerodynamic net. Available in standard 1" webbing. Colors Red, Blue or Black.

- 35052** Mini trucks (47" - 56")
- 35072** Fleet-side trucks (61" - 70")

WINDOW NETS

Required by most race-sanctioning organizations, these nets serve to keep the driver's arms contained within the vehicle in case of accidents. Please pay close attention to the net mounting requirements of each particular association. Deist window nets feature heavy-duty nylon netting with full perimeter webbing.

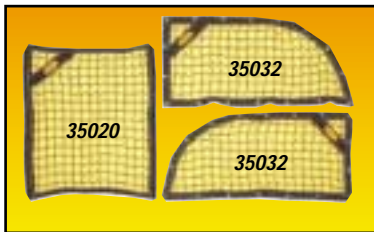

- 35012** Mini-truck window nets with snaps (pair)
- 35013** 1" webbing 18" x 24" Black
- 35014** 1" webbing 18" x 24" Red, Blue, Yellow
- 35015** 1" webbing Truck 21" X 22"
- 35016** 1" webbing angular 17" X 31"
- 35017** 1" webbing angular Superspeedway 16-1/2" X 31"
- 35019** Installation kit Lever Latch 1" flat bar
- 35020** Rectangular, rod mount 22" X 27" Net
- 35022** Rectangular, snap mount 22" X 27" Net
- 35032** VW early, snap mount 1964 & earlier
- 35042** VW late, snap mount 1965 & later

30.



COLD FIRE 302

Cold Fire 302 is a fire suppressing agent for Class B oil/fuel fires. It suppresses quickly, prevents reflash, is safe to store, handle and use. Leaves virtually no residue and is environmentally safe. On Class B fires, the chemical encapsulates the oil and prevents burning and reignition. Cold Fire 302 has the advantages of foam and dry chemical without the mess. Cold Fire suppressants are UL listed and approved by many state agencies. **See page 21 for more details.**

LIMIT STRAPS

Designed to prevent shock absorber damage from suspension over-extension. Length should be approximately 20% shorter than maximum suspension travel, when measuring in static position. **38000** Limit straps, pair (specify length)



JEEP HARNESSES

- 6022JO** 2" Shoulder Harness.
 - 6033JO** 3" Shoulder Harness.
 - 6232JO** 3" Lap belt Snap-In.
 - 6232J5** Jeep 5 pt. assembly.
- See pages 11 thru 17 for more details.**

KIDNEY BELT

Available in Small, Medium & Large sizes. **06330** Kidney Belt.



TREE SAVER

The ideal compliment to any winch, Deist's "Tree Saver" provides a secure non-slip anchor while preventing cable damage to trees, fence posts, etc.

- 41406** Tree Saver (6' high-strength nylon strap)



SHOCK TOW

A virtual "must" for any off-roader or outdoors person. The Deist shock tow is used to pull vehicles out of mud, sand, snow, etc. It is made of special high-stretch nylon webbing, and because the Shock Tow stretches to a point past its static length and rebounds, it actually multiplies a vehicle's pulling power.

- 47000** Storage bag for shock tow
- 47120** 20' 1" Webbing 6,000 lbs (no bag)
- 47220** 20' 2" Webbing 10,000 lbs (no bag)
- 47420** 20' 4" Webbing 20,000 lbs (no bag)
- 47520** 20' 2" Webbing 15,000 lbs (no bag)
- 47530** 30' 2" Webbing 15,000 lbs (no bag)

Order Line: (800) 383-3478 | Tech Line: (818) 240-7866 | Fax Line: (818) 244-9230



STOCK CAR

WINDOW NETS

See Page 30 for more details

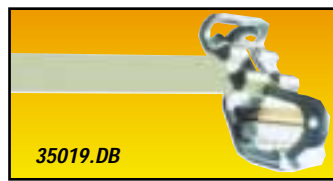
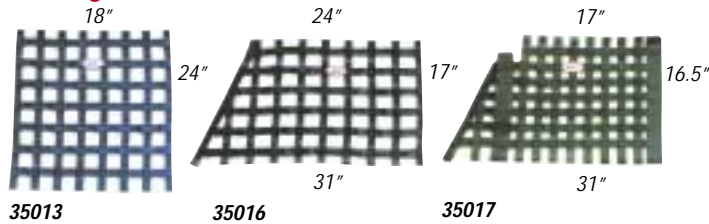

RE-FUELING GLOVES

Knit Nomex® back, exclusive "Fuel Barrier" and leather palm. Available in Red, Blue or Black. **Custom colors available. See page 8 for more details.**

04300 Re-fueling Gloves

SUPER SPEEDWAY BOOTS

Deist Safety now offers the ultimate in SuperSpeedway safety, comfort and style! Our new line of Super Speedway driving shoes are available in a mid top design. Shoes are lined with a padded Kevlar® inner liner and have a custom heat shield outer shell to reflect the heat. Available in Men's size 6 to 13 and in half sizes. Black, Red, Gray or Blue. **See page 8 for more details on Crew Shoes and Driving Boots.**



08000 Mid Top Super Speedway Driving Boots

NYLON STEERING HUB PAD

Our steering wheel pad has Fire Retardant foam and is covered with Dupont® 400 denier Antron/Nylon material. Available to fit 3 or 4 spoke steering wheels. Available in Black. **Custom colors available.**

80226 Steering Wheel Hub Pad 4 spoke

80226.3 Steering Wheel Hub Pad 3 spoke



KOOL FUEL BY DEIST!

Keeping fuel cool between pit stops has always been a problem. Now Deist solves the **HOT FUEL** dilemma with the "Kool Fuel" Can Cover. Just wrap your fuel dump can with the bright Silver aluminized fire retardant cover, then slip our Kool Pads in the inside pockets. Presto, no more **HOT FUEL** into a already Hot race car. **91500** Dump can cover and Kool pads.



HIGH BACK SEAT

This "Lay Back" seat is designed for stock cars or modifieds and offers excellent support for high speed cornering. Standard features include an extruded aluminum border welded to the perimeter of the seat and an optional padded black vinyl cover. Made from .090" aluminum.

80500 Seat only

80502 Upholstery only



See page 24 for Poly seats.



RE-FUELING APRONS

Re-fueling aprons are made from a fire retardant, fuel resistant Silver coated material. This will stop any fuel spillage from penetrating your race uniform. Also, regular crew apron available.

See page 10 for more details.

80224 Re-Fueling Apron crew (Silver)
YOUR LOGO EMBROIDERED AT ADDITIONAL COST

RE-FUELING SUIT

Deist Safety offers the most advanced re-fueling suits available! Our re-fueling suits and gloves offer a comfortable fit, ease of mobility, outstanding fire protection, and most important is our exclusive "**LIQUID BARRIER**" protection. This liquid barrier protection shields the user from harmful liquids such as hot fuel, oil & water. **00800** Re-Fueling Suit

HALON 1301

Our Halon 1301 Systems, which utilize lightweight 6061-T6 aluminum bottles, is ideal for the weight conscious racer. **See Page 21 for more details.**



SHIFT BOOT COVER - NOMEX

Made of 2 layer knit Nomex® material. Used as a secondary cover over your existing rubber boot. **Custom colors available.**

80228 Shift Boot Cover 2 layer



31.

Order Line: (800) 383-3478 | Tech Line: (818) 240-7866 | Fax Line: (818) 244-9230

DEIST

Safety



DEIST SAFETY

641 Sonora Avenue/Glendale, CA 91201-2399

Phone: (800) 383-3478

(818) 240-7866

Fax: (800) 403-3478

(818) 244-9230

E-Mail: deistsaf@ix.netcom.com

www.deist.com